



AH118 / ECG099

1/4 Watt, High Linearity InGaP HBT Amplifier

The Communications Edge™

Product Information

Product Features

- 60 – 3500 MHz
- +24.7 dBm P1dB
- +40.5 dBm Output IP3
- 20.4 dB Gain @ 900 MHz
- 16.5 dB Gain @ 1900 MHz
- +5V Single Positive Supply
- Available in lead-free / green SOT-89 SMT Package Style

Applications

- Final stage amplifiers for Repeaters
- Mobile Infrastructure
- DBS / WLL / W-LAN
- Defense / Homeland Security

Product Description

The AH118 / ECG099 is a high dynamic range driver amplifier in a low-cost surface mount package. The InGaP/GaAs HBT is able to achieve high performance across a broad range with +40.5 dBm OIP3 and +24.7 dBm of compressed 1dB power. The AH118 / ECG099 is available in a lead-free/green/RoHS-compliant SOT-89 package. All devices are 100% RF and DC tested.

The AH118 / ECG099 is targeted for use as a driver amplifier in wireless infrastructure where high linearity and medium power is required. Internal biasing allows the AH118 to maintain high linearity over temperature and operate directly off a single +5V supply. This combination makes the device an excellent candidate for transceiver line cards in current and next generation multi-carrier 3G base stations.

Functional Diagram

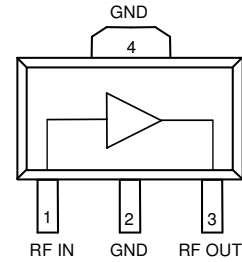

Function	Pin No.
Input / Base	1
Output / Collector	3
Ground	2, 4

Specifications ⁽¹⁾

Parameter	Units	Min	Typ	Max
Operational Bandwidth	MHz	60		3500
Test Frequency	MHz		1900	
Gain	dB	13.5	16.5	
Input Return Loss	dB		12	
Output Return Loss	dB		18	
Output P1dB	dBm	+23	+24.7	
Output IP3 ⁽²⁾	dBm	+39.5	+40.5	
IS-95A Channel Power @ -45 dBc ACPR	dBm		+18	
W-CDMA Channel Power @ -45 dBc ACLR, 2140 MHz	dBm		+16.7	
Noise Figure	dB		4.3	
Operating Current Range	mA	140	160	175
Device Voltage	V		+5	

1. Test conditions unless otherwise noted: 25°C, Vsupply = +5 V, in tuned application circuit.
 2. 3OIP measured with two tones at an output power of +11 dBm/tone separated by 1 MHz. The suppression on the largest IM3 product is used to calculate the 3OIP using a 2:1 rule.

Typical Performance ⁽³⁾

Parameter	Units	Typical		
Frequency	MHz	900	1900	2140
S21 - Gain	dB	20.4	16.5	16.3
S11 - Input R.L.	dB	-15	-12	-15
S22 - Output R.L.	dB	-12	-18	-16
Output P1dB	dBm	+24.2	+24.7	+24.7
Output IP3	dBm	+40	+40.5	+40.5
IS-95A Channel Power @ -45 dBc ACPR	dBm	+18.2	+18	
W-CDMA Channel Power @ -45 dBc ACLR	dBm			+16.7
Noise Figure	dB	4.0	4.3	4.8
Supply Bias		+5 V @ 160 mA		

3. Typical parameters reflect performance in a tuned application circuit: Vsupply = +5 V, I = 160 mA, +25° C

Absolute Maximum Rating

Parameter	Rating
Operating Case Temperature	-40 to +85 °C
Storage Temperature	-65 to +150 °C
RF Input Power (continuous)	+15 dBm
Device Voltage	+6 V
Device Current	220 mA
Junction Temperature	+250 °C

Operation of this device above any of these parameters may cause permanent damage.

Ordering Information

Part No.	Description
AH118-89	High Linearity InGaP HBT Amplifier (lead-tin SOT-89 Pkg)
ECG099B	High Linearity InGaP HBT Amplifier (lead-tin SOT-89 Pkg)
AH118-89G	High Linearity InGaP HBT Amplifier (lead-free/green/RoHS-compliant SOT-89 Pkg)
AH118-89PCB900	900 MHz Evaluation Board
AH118-89PCB1900	1900 MHz Evaluation Board
AH118-89PCB2140	2140 MHz Evaluation Board

Specifications and information are subject to change without notice



Typical Device Data

S-Parameters ($V_{Device} = +5\text{ V}$, $I_{CC} = 160\text{ mA}$, 25° C , unmatched 50 ohm system)

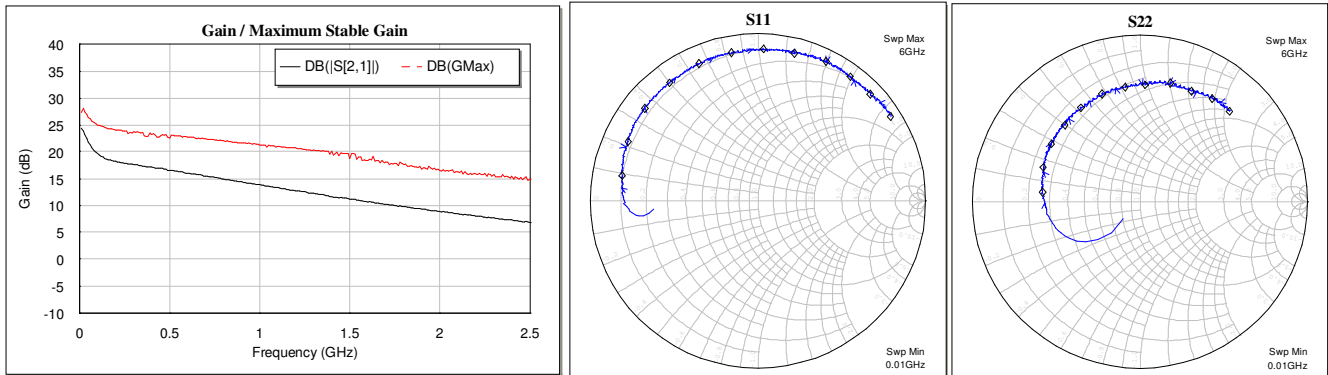

Notes:

The gain for the unmatched device in 50 ohm system is shown as the trace in black color. For a tuned circuit for a particular frequency, it is expected that actual gain will be higher, up to the maximum stable gain. The maximum stable gain is shown in the dashed red line. The impedance plots are shown from 50 – 6000 MHz, with markers placed at 0.5 – 6.0 GHz in 0.5 GHz increments.

S-Parameters ($V_{Device} = +5\text{ V}$, $I_{CC} = 160\text{ mA}$, 25° C , unmatched 50 ohm system, calibrated to device leads)

Freq (MHz)	S11 (dB)	S11 (ang)	S21 (dB)	S21 (ang)	S12 (dB)	S12 (ang)	S22 (dB)	S22 (ang)
50	-2.69	-173.38	21.74	153.70	-31.02	11.24	-7.02	-148.17
100	-2.16	-177.19	19.63	150.82	-30.31	7.90	-5.57	-162.45
200	-1.91	178.30	18.22	148.19	-29.87	5.01	-5.06	-173.51
400	-1.77	172.47	17.13	135.41	-29.83	4.07	-4.77	177.87
600	-1.60	166.83	15.99	121.91	-29.49	2.79	-4.60	171.65
800	-1.45	161.09	14.97	109.02	-29.18	2.11	-4.44	166.08
1000	-1.40	155.39	13.84	97.28	-28.70	1.64	-4.26	160.40
1200	-1.25	149.59	12.76	86.83	-28.63	-0.09	-4.14	155.01
1400	-1.20	143.79	11.71	76.95	-28.30	-1.34	-3.97	149.63
1600	-1.17	137.57	10.63	68.15	-27.94	-4.47	-4.00	144.03
1800	-1.13	132.05	9.75	59.55	-27.63	-7.00	-3.86	139.02
2000	-1.11	126.72	8.88	52.22	-27.51	-8.43	-3.84	134.24
2200	-1.05	121.50	8.00	45.09	-27.06	-11.00	-3.62	129.30
2400	-0.99	115.58	7.31	37.40	-27.02	-14.19	-3.55	124.42
2600	-0.93	110.41	6.52	30.66	-26.78	-18.24	-3.46	119.42
2800	-0.95	105.30	5.73	23.51	-26.66	-20.10	-3.34	114.26
3000	-0.92	100.11	5.05	17.07	-26.61	-23.28	-3.30	109.29

Application Circuit PC Board Layout

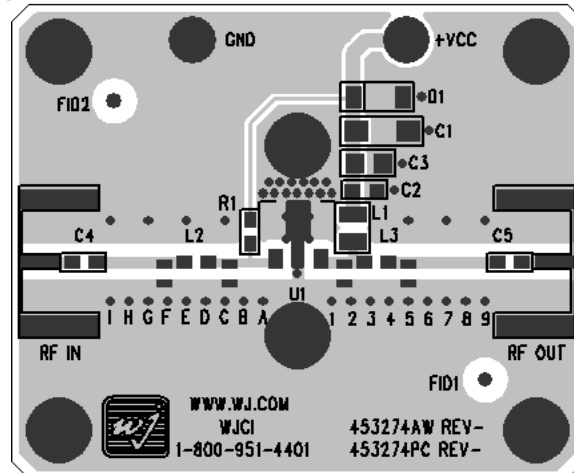

Circuit Board Material: .062" total thickness with a .014" Getek top RF layer, 4 layers (other layers added for rigidity),

1 oz copper, Microstrip line details: width = .026", spacing = .026"

The silk screen markers 'A', 'B', 'C', etc. and '1', '2', '3', etc. are used as placemarkers for the input and output tuning.

Specifications and information are subject to change without notice



900 MHz Application Circuit (AH118-89PCB900)

Typical RF Performance at 25°C

Frequency	900 MHz
S21 – Gain	20.4 dB
S11 – Input Return Loss	-15 dB
S22 – Output Return Loss	-12 dB
Output P1dB	+24.2 dBm
Output IP3 (+11 dBm/ tone, 1 MHz spacing)	+40 dBm
Channel Power (@ -45 dBc ACPR, IS-95 9 channels fwd)	+18.2 dBm
Noise Figure	4 dB
Device / Supply Voltage	+5 V
Quiescent Current	160 mA

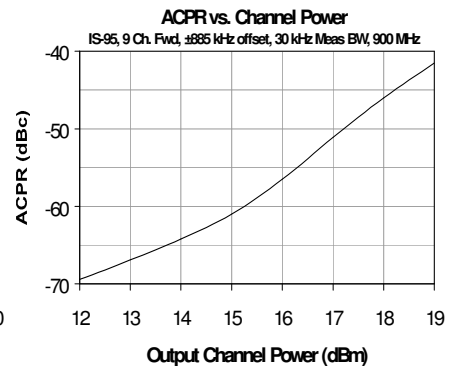
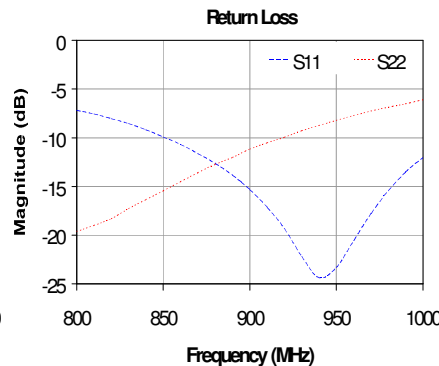
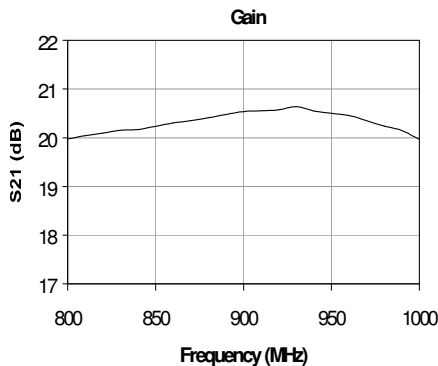
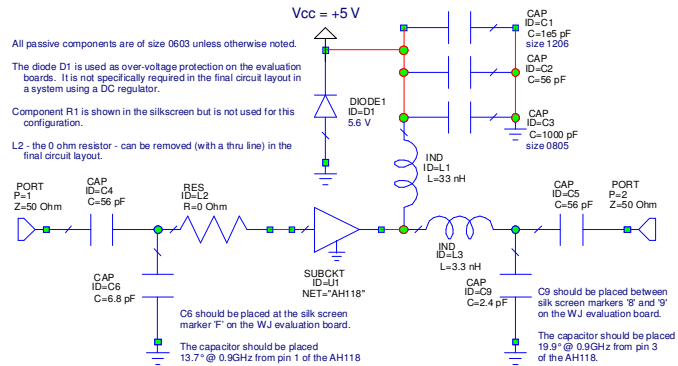

1900 MHz Application Circuit (AH118-89PCB1900)

Typical RF Performance at 25°C

Frequency	1900 MHz
S21 – Gain	16.5 dB
S11 – Input Return Loss	-12 dB
S22 – Output Return Loss	-18 dB
Output P1dB	+24.7 dBm
Output IP3 (+11 dBm/ tone, 1 MHz spacing)	+40.5 dBm
Channel Power (@ -45 dBc ACPR, IS-95 9 channels fwd)	+18 dBm
Noise Figure	4.3 dB
Device / Supply Voltage	+5 V
Quiescent Current	160 mA

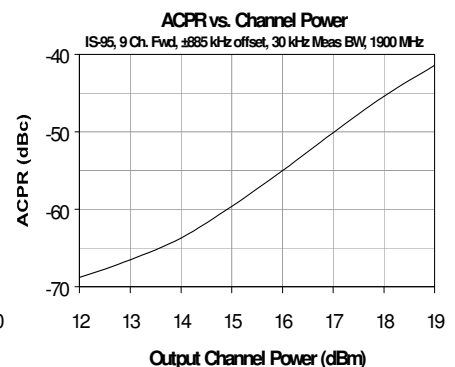
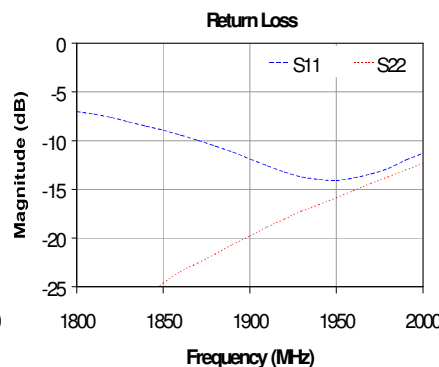
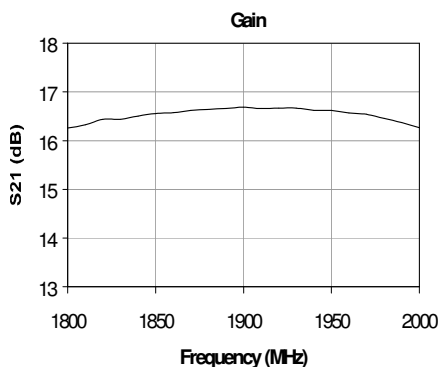
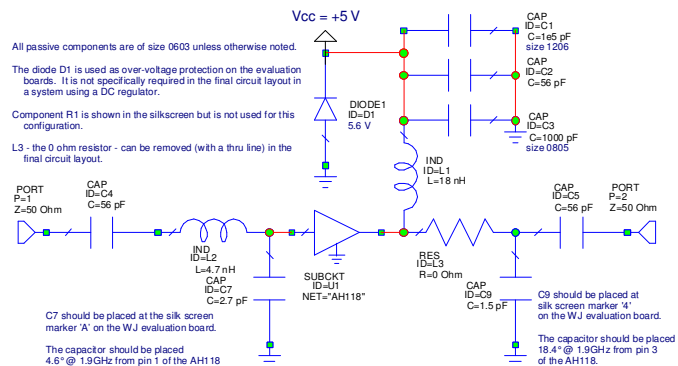

Specifications and information are subject to change without notice



2140 MHz Application Circuit (AH118-89PCB2140)

Typical RF Performance at 25°C

Frequency	2140 MHz
S21 – Gain	16.3 dB
S11 – Input Return Loss	-15 dB
S22 – Output Return Loss	-16 dB
Output P1dB	+24.7 dBm
Output IP3 (+11 dBm / tone, 1 MHz spacing)	+40.5 dBm
Channel Power (@-45 dBc ACPR, IS-95 9 channels fwd)	+16.7 dBm
Noise Figure	4.8 dB
Device / Supply Voltage	+5 V
Quiescent Current	160 mA

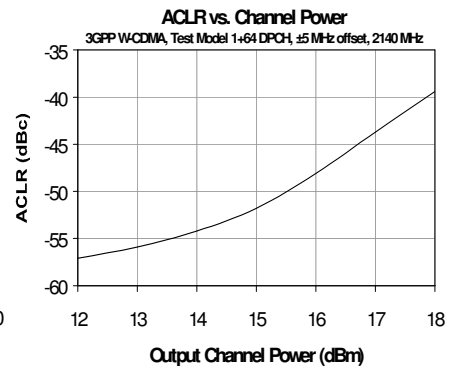
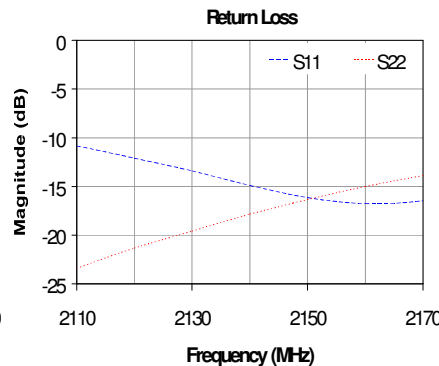
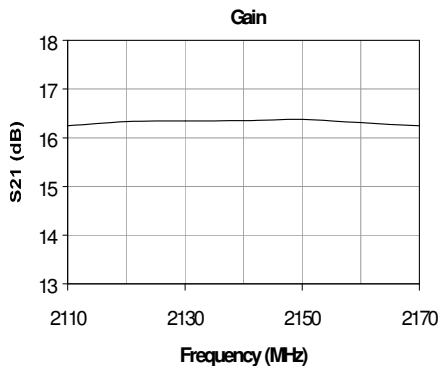
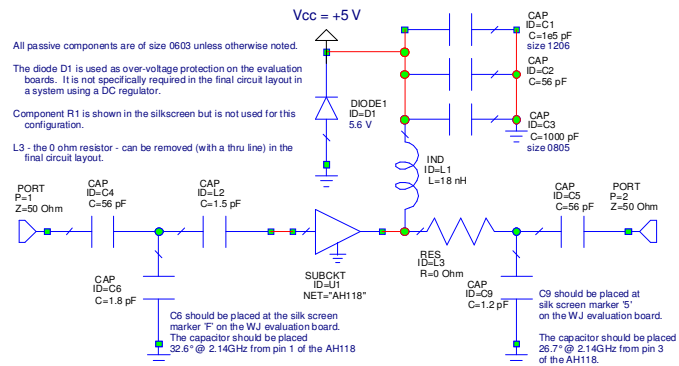

3500 MHz Application Circuit

Typical RF Performance at 25°C

Frequency	3500 MHz
S21 – Gain	8.5 dB
S11 – Input Return Loss	-12 dB
S22 – Output Return Loss	-12 dB
Output P1dB	+23.5 dBm
Output IP3 (+11 dBm / tone, 1 MHz spacing)	+38.5 dBm
Noise Figure	5.0 dB
Device / Supply Voltage	+5 V
Quiescent Current	160 mA

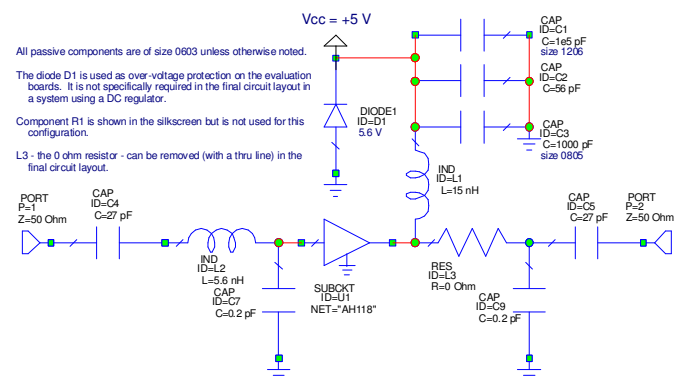



AH118 / ECG099

1/4 Watt, High Linearity InGaP HBT Amplifier

The Communications Edge™

Product Information

AH118-89 (SOT-89 Package) Mechanical Information

This package may contain lead-bearing materials. The plating material on the leads is SnPb.

Outline Drawing

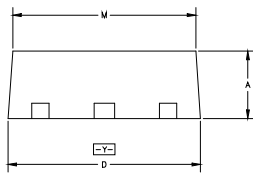
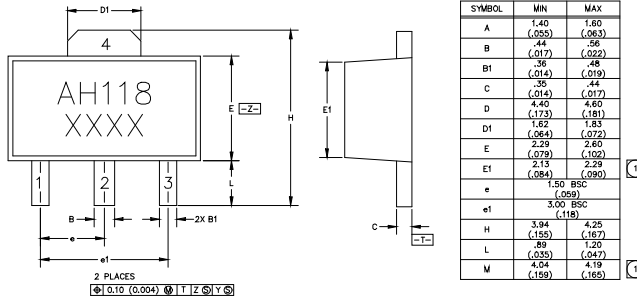

NOTES:
 1. DIMENSIONS CONFORM WITH JEDEC TO-243C EXCEPT WHERE INDICATED.
 2. DIMENSIONS ARE EXPRESSED IN MILLIMETERS(INCHES).
 3. DIMENSIONING AND TOLERANCING IAW ANSI Y14.5M

Land Pattern

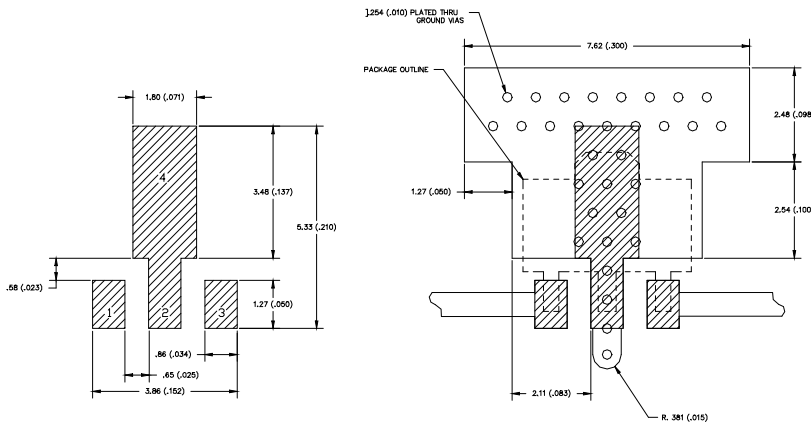

Thermal Specifications

Parameter	Rating
Operating Case Temperature	-40 to +85° C
Thermal Resistance ⁽¹⁾	92° C / W
Junction Temperature ⁽²⁾	159° C

Notes:

- The thermal resistance is referenced from the hottest part of the junction to the ground tab (pin 4).
- This corresponds to the typical biasing condition of +5V, 160 mA at an 85° C ground tab temperature. A minimum MTTF of 1 million hours is achieved for junction temperatures below 247° C.

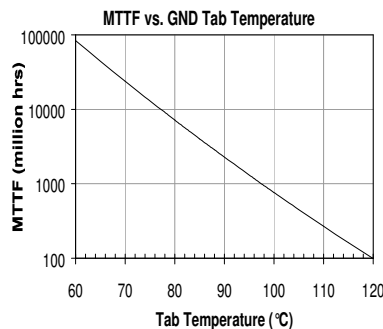

Product Marking

The component will be marked with an "AH118" designator with an alphanumeric lot code on the top surface of the package.

Tape and reel specification for this part is located on the website in the "Application Notes" section.

ESD / MSL Information



Caution! ESD sensitive device.

ESD Rating: Class 1A
 Value: Passes between 250 and 500V
 Test: Human Body Model (HBM)
 Standard: JEDEC Standard JESD22-A114

MSL Rating: Level 3 at +235° C convection reflow
 Standard: JEDEC Standard J-STD-020

Mounting Config. Notes

- Ground / thermal vias are critical for the proper performance of this device. Vias should use a .35mm (#80 / .0135") diameter drill and have a final plated thru diameter of .25 mm (.010").
- Add as much copper as possible to inner and outer layers near the part to ensure optimal thermal performance.
- Mounting screws can be added near the part to fasten the board to a heatsink. Ensure that the ground / thermal via region contacts the heatsink.
- Do not put solder mask on the backside of the PC board in the region where the board contacts the heatsink.
- RF trace width depends upon the PC board material and construction.
- Use 1 oz. Copper minimum.
- All dimensions are in millimeters (inches). Angles are in degrees.



AH118 / ECG099

1/4 Watt, High Linearity InGaP HBT Amplifier

The Communications Edge™

Product Information

AH118-89G (Green / Lead-free SOT-89 Package) Mechanical Information

This package is lead-free/Green/RoHS-compliant. It is compatible with both lead-free (maximum 260°C reflow temperature) and leaded (maximum 245°C reflow temperature) soldering processes. The plating material on the leads is NiPdAu.

Outline Drawing

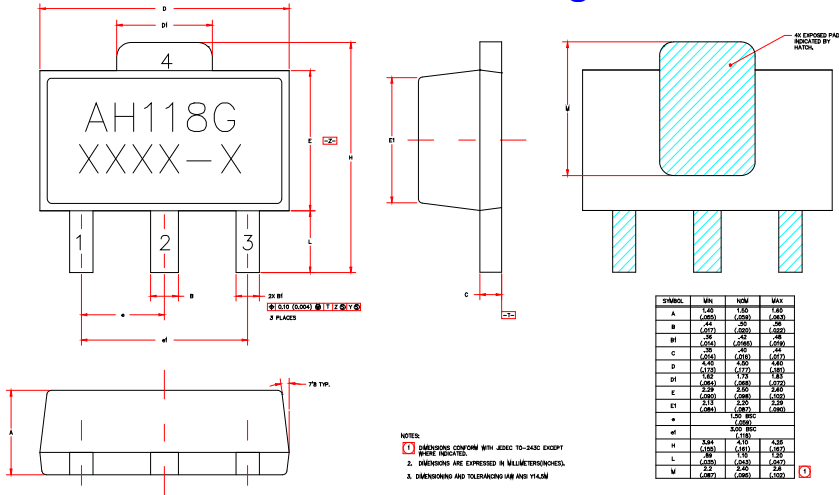

Product Marking

The component will be marked with an "AH118G" designator with an alphanumeric lot code on the top surface of the package.

Tape and reel specifications for this part are located on the website in the "Application Notes" section.

MSL / ESD Rating



Caution! ESD sensitive device.

ESD Rating: Class 1A

Value: Passes between 250 and 500V

Test: Human Body Model (HBM)

Standard: JEDEC Standard JESD22-A114

MSL Rating: Level 3 at +260° C convection reflow

Standard: JEDEC Standard J-STD-020

Land Pattern

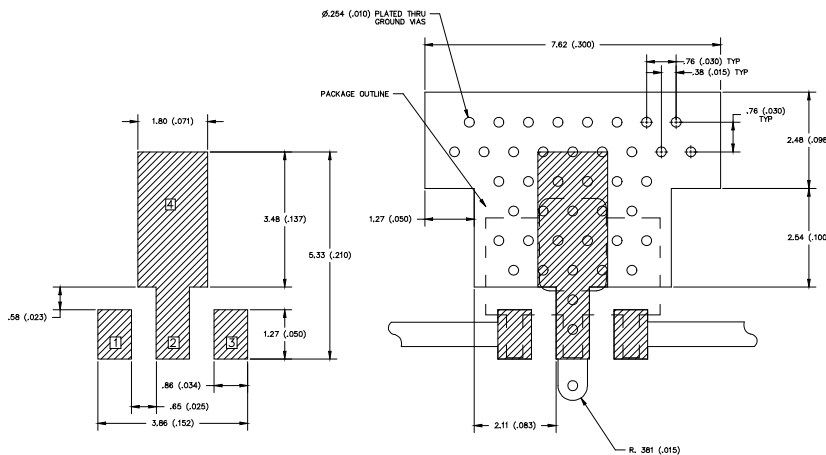

Mounting Config. Notes

1. Ground / thermal vias are critical for the proper performance of this device. Vias should use a .35mm (#80 / .0135") diameter drill and have a final plated thru diameter of .25 mm (.010").
2. Add as much copper as possible to inner and outer layers near the part to ensure optimal thermal performance.
3. Mounting screws can be added near the part to fasten the board to a heatsink. Ensure that the ground / thermal via region contacts the heatsink.
4. Do not put solder mask on the backside of the PC board in the region where the board contacts the heatsink.
5. RF trace width depends upon the PC board material and construction.
6. Use 1 oz. Copper minimum.
7. All dimensions are in millimeters (inches). Angles are in degrees.

Thermal Specifications

Parameter	Rating
Operating Case Temperature	-40 to +85° C
Thermal Resistance ⁽¹⁾	92° C / W
Junction Temperature ⁽²⁾	159° C

Notes:

1. The thermal resistance is referenced from the hottest part of the junction to the ground tab (pin 4).
2. This corresponds to the typical biasing condition of +5V, 160 mA at an 85° C ground tab temperature. A minimum MTTF of 1 million hours is achieved for junction temperatures below 247° C.

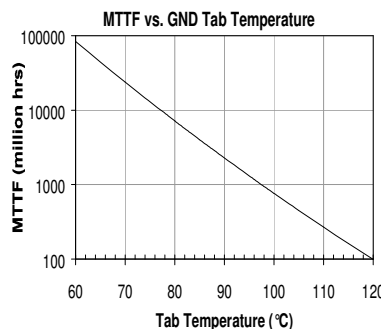

Specifications and information are subject to change without notice



ECG099B (SOT-89 Package) Mechanical Information

This package may contain lead-bearing materials. The plating material on the leads is SnPb.

Outline Drawing

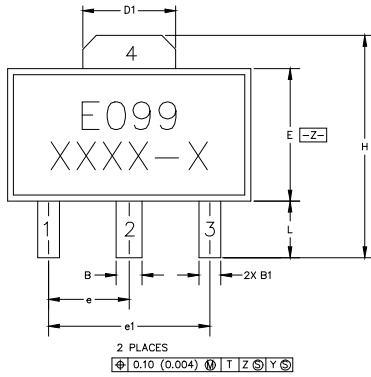

SYMBOL	MIN	MAX
A	1.40 (.055)	1.60 (.063)
B	.44 (.017)	.56 (.022)
B1	.36 (.014)	.48 (.019)
C	.35 (.014)	.44 (.017)
D	4.40 (.173)	4.60 (.181)
D1	1.62 (.064)	1.83 (.072)
E	2.29 (.079)	2.60 (.102)
E1	2.13 (.084)	2.29 (.090)
e	1.50 BSC (.059)	
e1	3.00 BSC (.118)	
H	3.94 (.155)	4.25 (.167)
L	.89 (.035)	1.20 (.047)
M	4.04 (.159)	4.19 (.165)

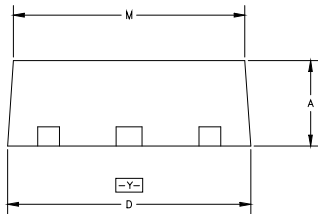

- NOTES:
1. DIMENSIONS CONFORM WITH JEDEC TO-243C EXCEPT WHERE INDICATED.
 2. DIMENSIONS ARE EXPRESSED IN MILLIMETERS(INCHES).
 3. DIMENSIONING AND TOLERANCING IAW ANSI Y14.5M

Product Marking

The component will be marked with an "E099" designator with an alphanumeric lot code on the top surface of the package.

Tape and reel specification for this part is located on the website in the "Application Notes" section.

ESD / MSL Information



Caution! ESD sensitive device.

ESD Rating: Class 1A
 Value: Passes between 250 and 500V
 Test: Human Body Model (HBM)
 Standard: JEDEC Standard JESD22-A114

MSL Rating: Level 3 at +235° C convection reflow
 Standard: JEDEC Standard J-STD-020

Mounting Config. Notes

1. Ground / thermal vias are critical for the proper performance of this device. Vias should use a .35mm (#80 / .0135") diameter drill and have a final plated thru diameter of .25mm (.010").
2. Add as much copper as possible to inner and outer layers near the part to ensure optimal thermal performance.
3. Mounting screws can be added near the part to fasten the board to a heatsink. Ensure that the ground / thermal via region contacts the heatsink.
4. Do not put solder mask on the backside of the PC board in the region where the board contacts the heatsink.
5. RF trace width depends upon the PC board material and construction.
6. Use 1 oz. Copper minimum.
7. All dimensions are in millimeters (inches). Angles are in degrees.

Land Pattern

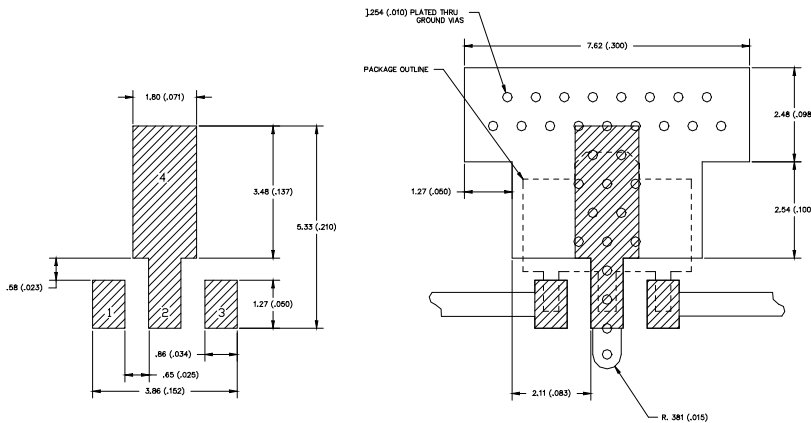

Thermal Specifications

Parameter	Rating
Operating Case Temperature	-40 to +85° C
Thermal Resistance ⁽¹⁾	92° C / W
Junction Temperature ⁽²⁾	159° C

Notes:

1. The thermal resistance is referenced from the hottest part of the junction to the ground tab (pin 4).
2. This corresponds to the typical biasing condition of +5V, 160 mA at an 85° C ground tab temperature. A minimum MTTF of 1 million hours is achieved for junction temperatures below 247° C.

